

DURASTRAINT™

CHILD RESTRAINT SEATS

The **DuraStraint™ Child Restraint Seat** features a versatile integrated child seat, that takes the guesswork out of what size passenger might come on board. This design allows you to convert the standard seat to accommodate kindergarten and Head start children from 20-50 pounds with a fold down child restraint insert. There is nothing extra to install, remove, or store. Offered in a single 22", or double 30", 37" and 39" sizes, its lightweight design also weighs 5-20 pounds less per seat over competitor's child restraint seating. All configurations are "seat belt ready" for school bus lap belts. A LATCH system is also offered with optional tether and/or lower anchor attachments to accommodate aftermarket infant car seats. Universal mounting accommodates floor bolting, L-Track or Uni-Strut floor track.



Designed to accommodate children weighing over 40 pounds, the **DuraStraint™ 3-Point Harness Seat** incorporates lap and shoulder belts. Its compact lightweight design saves 5-20 pounds per seat and provides 2" of extra knee space over other 3-point harness seats. It is offered in 22", 30", 37" and 45" widths and has the same seat back thickness as standard seating, and costs up to 20% less than competitor's 3-point seating. An added benefit of this design is that belts, retractors, and hardware may be serviced without upholstery removal or seat disassembly.

Collins Bus Corporation has designed, tested, and now manufactures a complete line of school bus certified seating options.

- All Collins seats provide a padded compartment around occupants.
- Energy-absorbing seat backs protect passengers in a forward or rear collision.
- Seats are tested weekly to ensure they continually meet or exceed requirements.

STANDARD SEATING

The standard **Collins School Bus Certified Bench Seats** provide a padded compartment around occupants. Strong steel seat frames form an integrated structure between floor, seat, and wall. These seat frames mount to the floor and to a continuous wall seat rail which runs the entire length of the wall. These seats are available in 22" for one person, 26", 30", and 37" for two persons or 39" and 45" for 3 persons.



All Collins Bus seats feature the same strong steel seat frames and utilize the same "foot print", making them interchangeable and retro-fittable in any Collins or Mid Bus floorplan.

CHILD RESTRAINT SEAT // // // //

- Key Features**
- Integrated design - nothing to install, remove or store when converting to the child restraint configuration.
 - Accommodates Head Start/Kindergarten age children 20-50 lbs.
 - Compact design - seat back thickness is the same as a standard seat, gaining as much as 2" knee space over other child restraint seats.
 - Lightweight design - saves 5-20 lbs per seat over other child restraint seats.
 - All configurations are "seat belt ready" for school bus lap belts.
 - LATCH system - optional tether and/or lower anchor attachment points available to accommodate aftermarket infant car seats.
 - Lower double-fold child restraint cushion - allows child to bend knees in the seated position while maintaining clearance to seat in front.
 - Removable child restraint insert - provides a soft, padded surface for child that is removable for easy laundering.
 - Universal mounting - accommodates floor bolting, L-Track, or Uni-Strut floor track.

- Available Sizes**
- 22" - 1 passenger or 1 child restraint position
 - 26" - 2 passengers or 1 child restraint position
 - 30" - 2 passengers or 1 child restraint position
 - 37" - 2 passengers or 2 child restraint positions
 - 39" - 3 passengers or 2 child restraint positions

- Compliance**
- FMVSS 210 (if equipped with optional lap belts)
 - FMVSS 213
 - FMVSS 222
 - FMVSS 225 (if equipped with optional LATCH system)
 - FMVSS 302
 - Fireblock Test (if equipped with optional fireblock upholstery) NY, OH, IL 28" "High Back" seat requirement.

3-POINT HARNESS SEAT // // // //

- Key Features**
- Combines benefits of school bus "compartmentalization" with the security of lap and shoulder belts.
 - Accommodates school children greater than 40 pounds.
 - Compact design - seat back thickness is the same as a standard seat, gaining as much as 2" of knee space over other 3-point harness seats.
 - Lightweight design saves 5-20 pounds per seat over other 3-point harness seats.
 - Belts, retractors, and hardware may be serviced without upholstery removal or seat disassembly.
 - LATCH system - optional tether and/or lower anchor attachment points available to accommodate aftermarket infant car seats.
 - Available with integrated child restraint seat(s) to accommodate children 20-50 pounds.

- Available Sizes**
- 22" - 1 passenger, also available with 1 child restraint position.
 - 30" - 2 passenger, also available with 1 child restraint position.
 - 37" - 2 passengers, also available with 2 child restraint positions.
 - 45" - 3 passengers

- Compliance**
- FMVSS 209 - Seat belt assemblies
 - FMVSS 210 - Seat belt assembly anchorages
 - FMVSS 213 - Child restraint systems (child restraint seat models)
 - FMVSS 222 - School bus passenger seating and crash protection
 - FMVSS 225 - Child restraint anchorage system (if equipped with optional LATCH system)
 - FMVSS 302 - Flammability of interior materials
 - Fireblock Test (if equipped with optional fireblock upholstery) NY, OH, IL 28" "High Back" seat requirement.

STANDARD SEAT // // // // //

- Key Features**
- The Collins school bus certified standard seats can be equipped with optional lap belts of up to 3 colors.
 - Seat spacing may be set between 24" to 28" knee space.
 - All seats are covered in heavy duty gray vinyl with 28" high backs and feature black powder coated steel frames.
 - Seats are mounted at the wall with continuous extruded seat rail.
 - Each seat leg is secured to the floor using three 1/2" diameter grade 5 flange-headed bolts with locking flanged nuts on the floor structure underside.
 - Seat track for floor-mounting is available as an option.
 - LATCH lower anchorages and/or tether attachment points may be added.

- Available Sizes**
- 22" - 1 passenger
 - 26" - 2 passengers
 - 30" - 2 passengers
 - 34" - 2 passengers
 - 37" - 2 passengers
 - 39" - 3 passengers
 - 45" - 3 passengers

- Compliance**
- FMVSS 222 - School bus seating and crash protection
 - FMVSS 302 - Flammability test

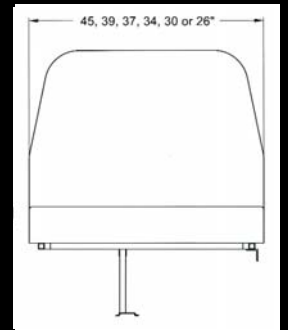
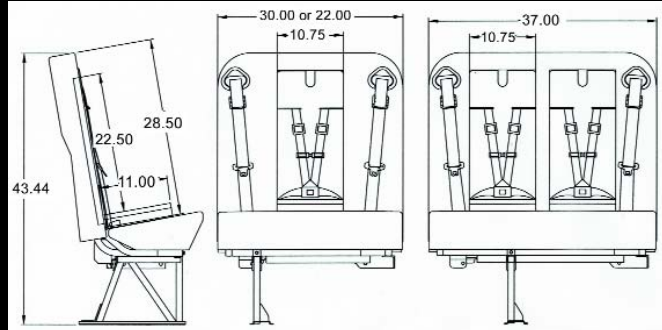
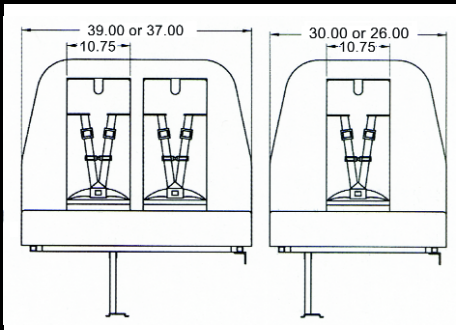

Collins Bus Corporation
415 West 6th Street
South Hutchinson, KS 67505
1.800.533.1850 • Fax: 620.662.3838

Mid Bus, Inc.
505 East Jefferson St.
Bluffton, Ohio 45817
1.800.358.6055 • Fax: 419.358.2400

Distributor:

www.collinsbuscorp.com

Due to ongoing engineering improvements, Collins reserves the right to make changes without notification.